



ROTOR AGILIS CRANKSET. QUICK INSTALLATION GUIDE.

AGILIS XC3 - 104/104/64 BCD
AGILIS XC2 - 110/74 BCD

Revised 03/2010

Non-Drive Side Assembly
DO NOT REMOVE THE BOLT

Drive Side Assembly
DO NOT DISASSEMBLE

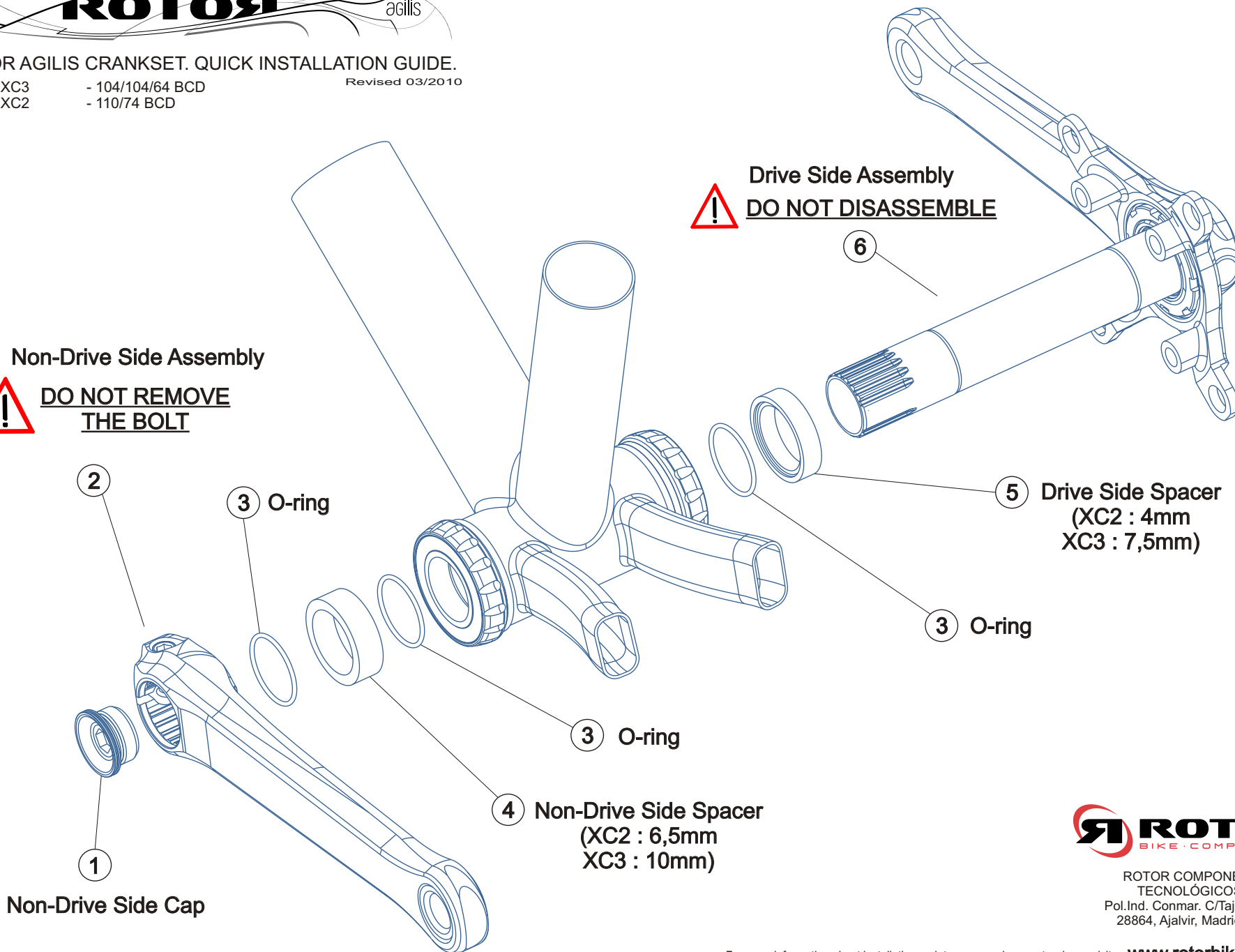

ROTOR COMPONENTES
TECNOLÓGICOS SL
Pol.Ind. Conmar. C/Tajo, Nave 6.
28864, Ajalvir, Madrid, Spain

For more information about installation, maintenance and warranty, please visit: www.rotorbike.com
info@rotorbike.com

#1. Bottom Bracket and Rings Installation.

Read ROTOR SABB or BB1, and Q-RINGS user manuals:

www.rotorbike.com

#2. Drive-Side Assembly Installation.

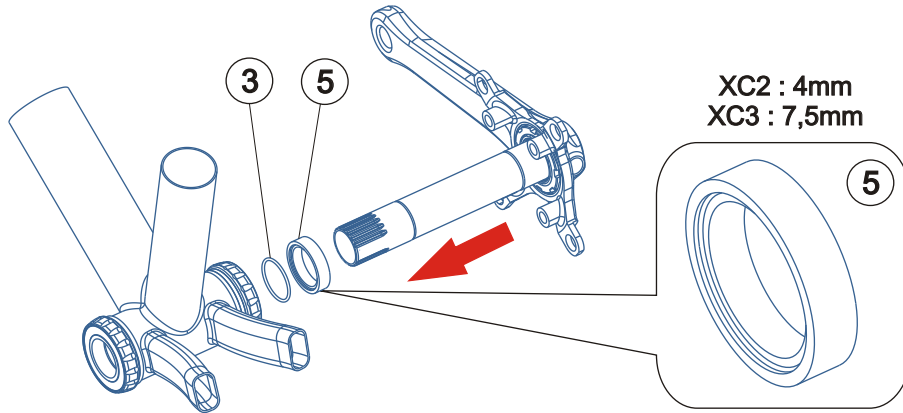

#3. Non-Drive Side Spacer / O-rings Installation.

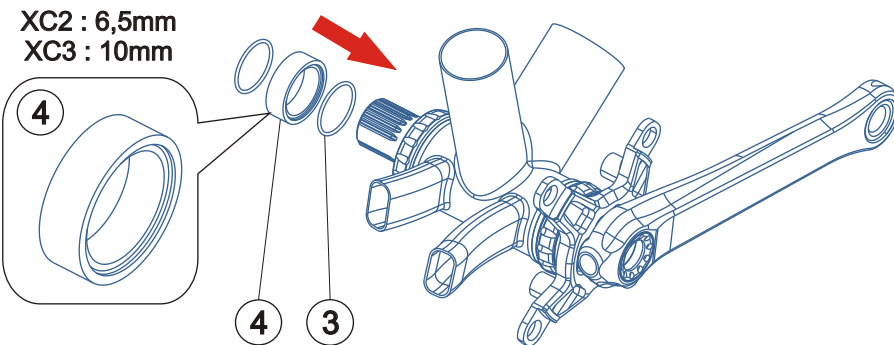

#4. Non-Drive Side Assembly preparation.

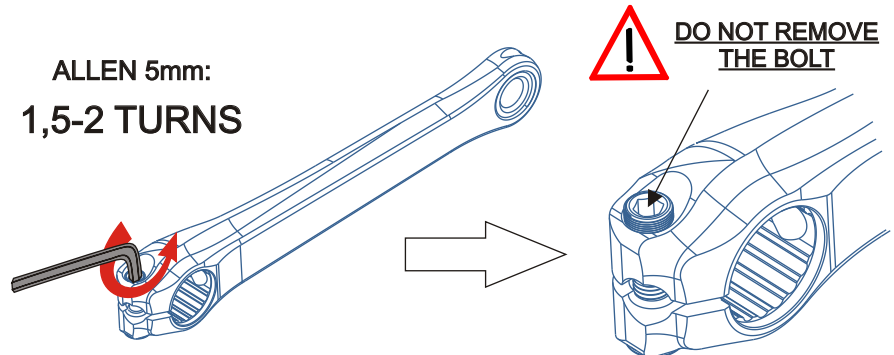

#5. Non-Drive Side Assembly Installation.

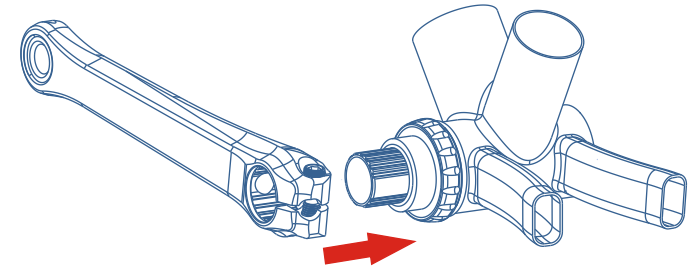

#6. Non-Drive Side Cap installation / preload.

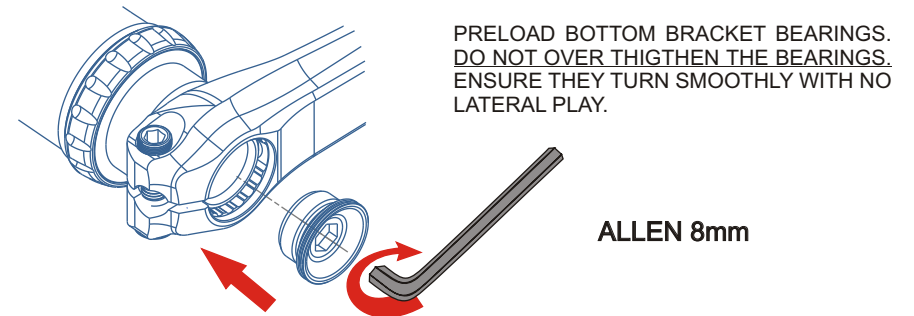

#7. Fixing the Non-Drive Side Assembly

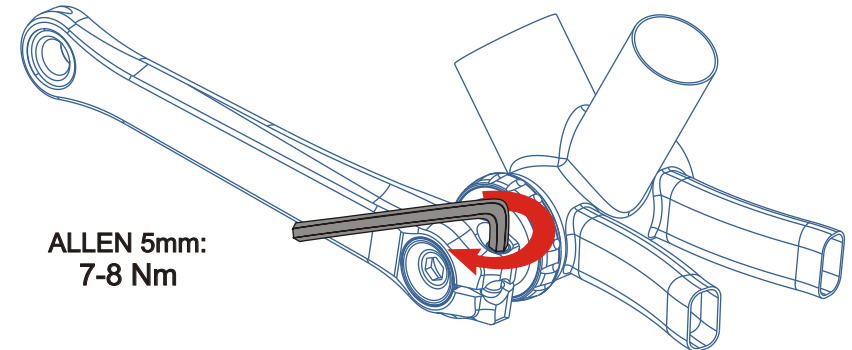

DISASSEMBLY.

1. Using a Allen 5mm key, unscrew the DTT bolt 2.5 turns (counter-clockwise). **WARNING: DO NOT REMOVE THE BOLT** from the Non-Drive Side arm.
2. Using a Allen 8mm key unscrew the Non-Drive Side Cap (counter-clockwise) and remove it.
3. Remove the Non-Drive Side arm and the O-ring from the axle.
4. Remove the Drive Side Assembly.